

SMEC

MCV 8500L

VERTICAL MACHINING CENTER

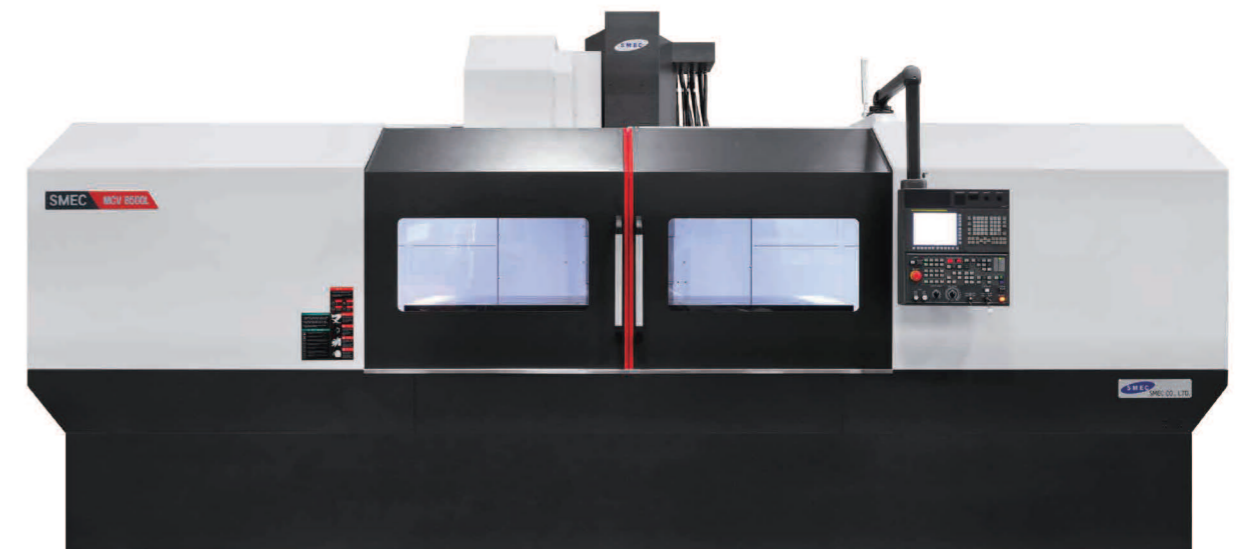

SMEC Co., Ltd.

157-10, Goldenroot-ro, Juchon-myeon,
Gimhae-si, Gyeongsangnam-do, Korea

Tel +82 55 340 4800

Fax +82 55 340 4740



www.esmec.com



<https://www.youtube.com/c/smecmachinetools>

SMEC
Smart One,
Global One

© SMEC 2020.06-NO.1



- 1988 - Started as Samsung Heavy Industries Machine Tools Business
- 1989 - Horizontal and vertical machining center technology partnership with OKK Japan
- 1991 - Turning center and vertical machining center technology partnership with Mori Seiki
- 1996 - 5-sided processing center technology partnership with Toshiba
- 1999 - Spun out from Samsung Aerospace Industries and established SMEC Co., Ltd

SMEC

Company

Engineering

Machine Tools

Samsung

MCV 8500L

High speed and precision
vertical machining center!
High rigidity arch structure!

- Low centered one piece Bed with triangle Rib design
- Biggest X axis stroke(MCV 8500L:2,540mm) and table in its class
- Realize high rigidity and precision with high rigidity Saddle and arch Column structure
- 6 rows Y axis LM guide way prevent overhang
- High speed and precision direct spindle



Direct head

Spindle Speed
12,000 rpm

Spindle Motor
11/15/18.5 kW

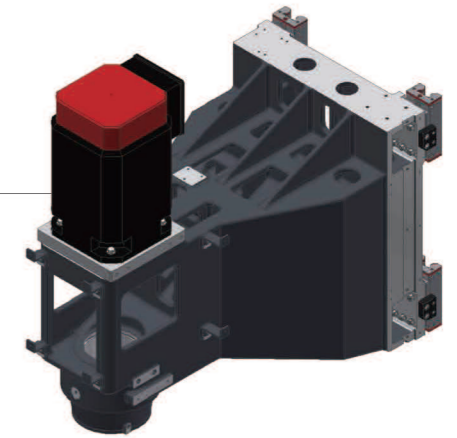

Spindle is sustained by 4 rows P4 speedy angular ball bearing reducing temperature increasing to realize high speed and precision machining.
By adopting Direct Drive type spindle minimize vibration to excellent machining for nonmetal surface finishing.
Motor direct type is connected by coupling without extra power transmission.

JACKET circulation cooling system

Adopting semipermanent Grease lubrication system on bearing, minimize thermal displacement by Jacket circulation cooling through Fan Cooler on bearing housing, showing stable performance to take longer spindle life time. Minimize thermal displacement by standard spindle motor base cooling system.

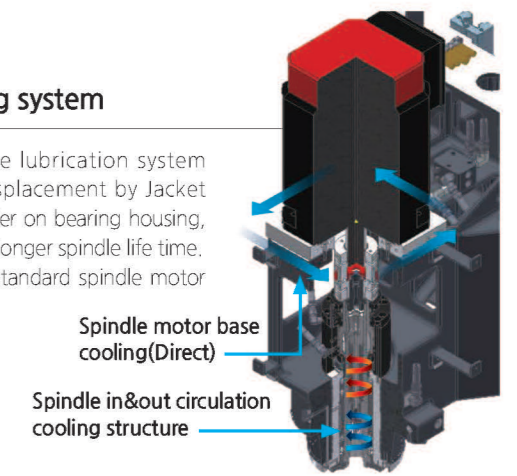

Dual Contact Spindle (BBT40)

Dual contact system to contact both main spindle surface and taper surface dually by measuring elastic deformation of spindle surface that occurs when main spindle is damped.
- Simultaneous contact to both main spindle surface and taper increases rigidity and reduces vibration.
- Increases machining capacity and surface roughness even under harsh condition.
- 100% compatible with existing tools.(BT40)

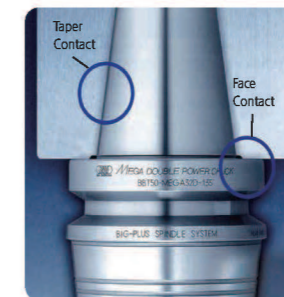

Big Plus BBT40
(Simultaneous Dual Contact)

Spindle Power & Torque Diagram

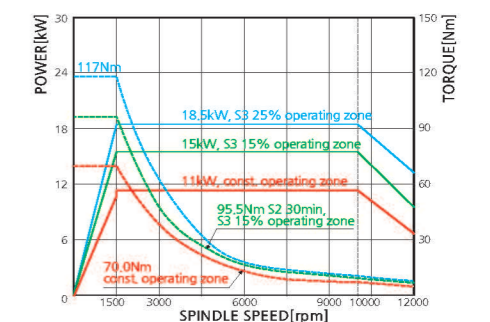

High-speed tool changer being driven by enhanced technologies



Twin arm type auto tool changer

It is Double swing arm swing type by memory random method and has no error during tool changing and minimize idle time.

Tool to Tool : **1.3(60Hz), 1.6(50Hz)**



Tool Magazine

By adopting 30ea tools as a standard having maximum tool storage capacity in its class. Also, shortest moving system design can set up next tool within short time.

Maximum tool capacity : **30ea**

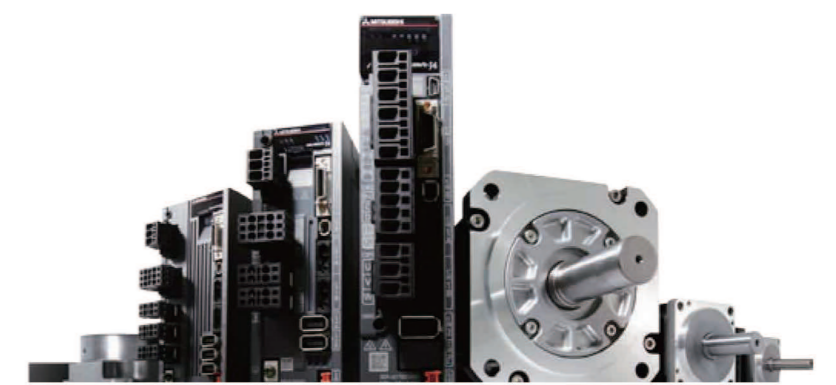

the most advanced mechanism of high-speed technology

HYD. UNIT

By using Hydraulic Unit from Germany product we realize that life time enhancement and lower power consumption with high reliability.

- Adopting accumulator
Enhance durability and tool change time by friction down of each internal part through reducing pumping time
- Epoch-making power consumption down(90%) by using pump when actuator is working(In case of HYD. UNIT)

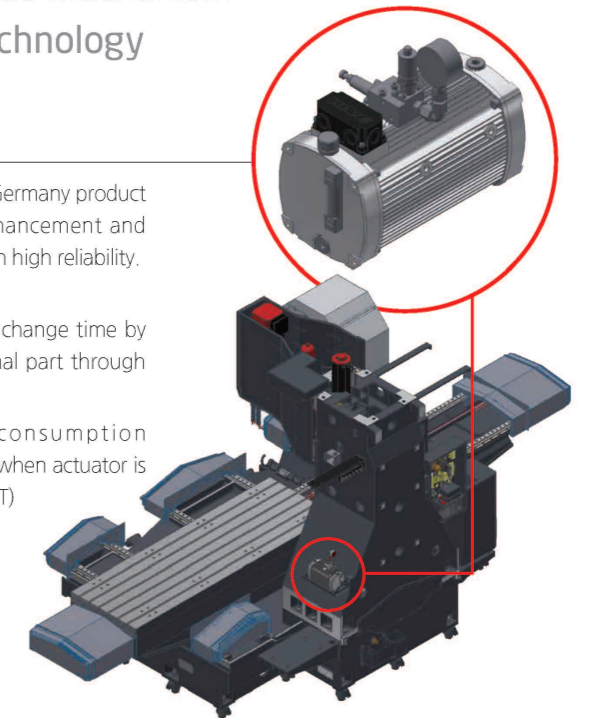

Ballscrew support with anchored ends / Opt. Nut cooling system(X, Y-Axis only)

Reduced changes to load on support bearing due to thermal displacement, while extending support bearing lifetime

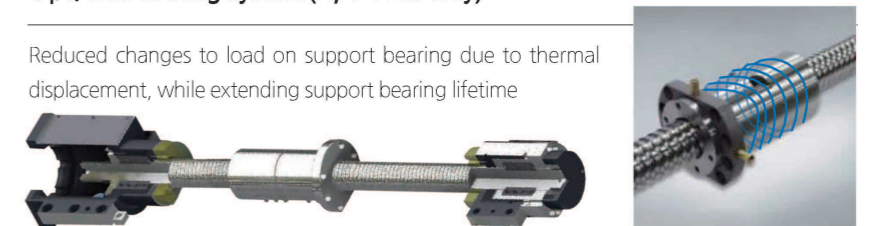

Largest-in-class internal area(MCV 8500L Spec.)

- Wide and stable stroke $\langle 2,540 \times 850 \times 650 \text{mm} \rangle$, $\langle \text{TABLE} : 2,600 \times 850 \text{mm} \rangle$
- Can fit up to $\varnothing 320$ rotary table - Easy wiring/piping for automation

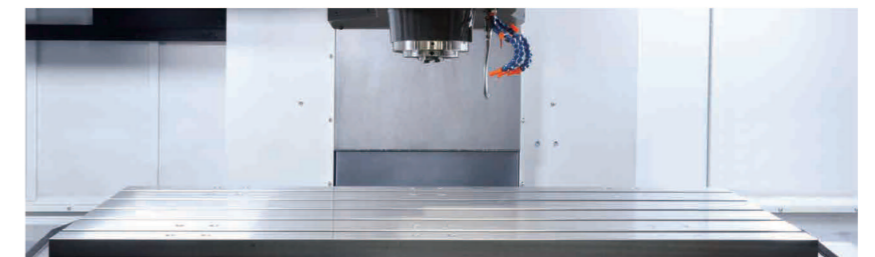

MCV 8500L

VERTICAL MACHINING CENTER

High rigidity Z axis arch column structure

By adopting arch column structure with optimal structural analysis realizing high rigidity and precision machining.

High precision machining is suitable depending on the Z axis linear scale options.

High rigidity Saddle without overhang on X axis

By maximum X axis stroke 2,540mm in its class and high rigidity saddle it is fit for various and stable as well as long work piece machining.

6 rows Guide way bed on Y axis

Bed has 6 rows sustaining method on Y axis and maximum span L/M Guide way structure in its class to minimize over hang.

X-Axis
2,540 mm

Y-Axis
850 mm

Z-Axis
650 mm



Pendant arm / Operation panel

Pendant/panel design by considering user space and convenience improve working environment



High efficiency Spindle Head Cooling System

For long-term continuous high-speed operation, a coolant system may be installed to maintain room temperature. The coolant system circulates coolant oil around the spindle bearings to prevent thermal expansion due to the spindle temperature, ensuring high precision machining.



Roller Guide Way

The use of LM Guides with superb responsiveness increased rapid traverse speeds and reduced non-cutting time while minimizing noise during travel.

- Strengthen speed, rigidity, durability
- Much better durability comparing with Ball LM Guide to realize precision moving and longer life time

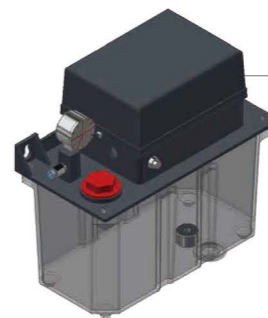

Automatic Lubrication Dispenser

Automatic lubrication dispenser that reliably dispenses the required amount of lubrication to the required travel axes. Lubrication is only dispensed when the travel axes is in operation, reducing the amount of lubrication that is consumed. When there is problem on lubrication line it shows warning message on a screen and stop the machine for users safety operation.

Fully enclosed Splash Guard!

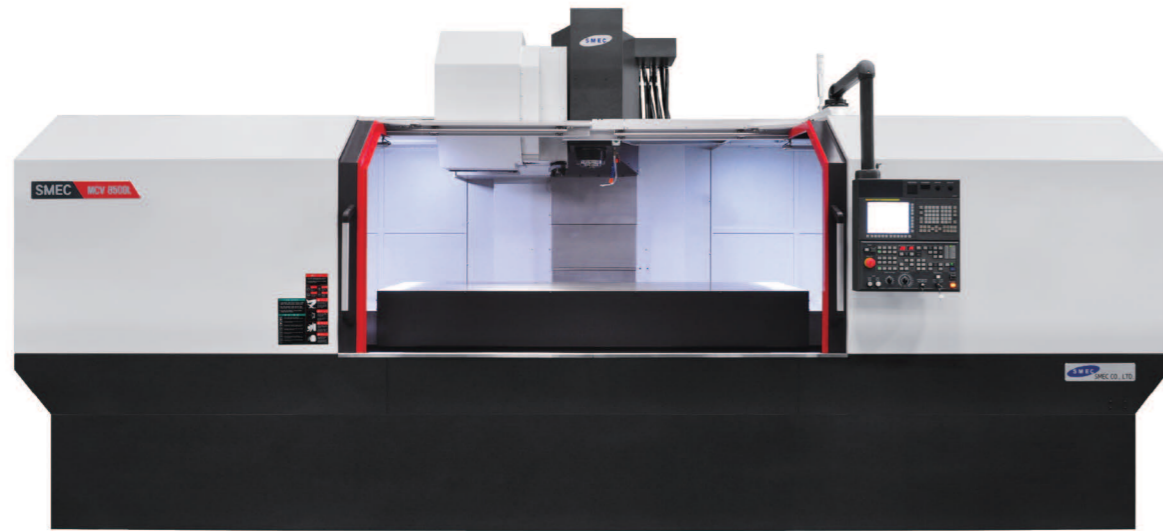

Enhanced chip disposal

- Forward discharge of 4set coil conveyor
- Coolant & Improved chip disposal

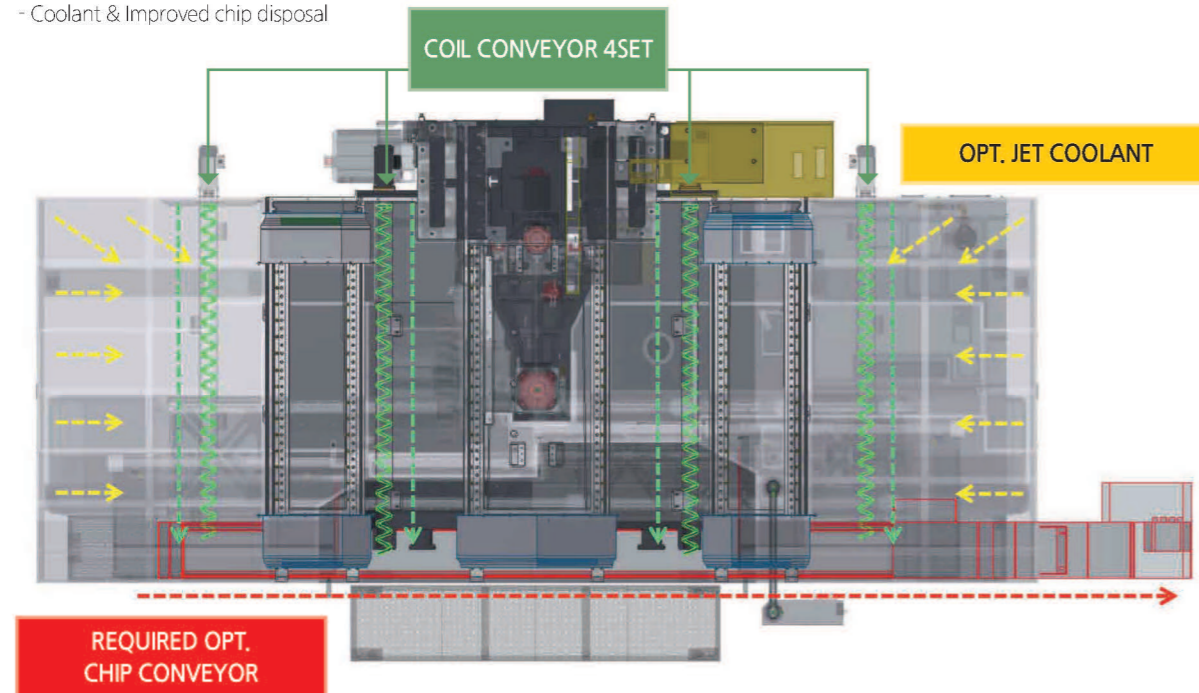

High rigidity & performance travel system

Travel type

Directly connecting with servo motor(Y/Z)

There is no intermediate channel to transmit power but using coupling and minimize back lash during axis moving

Roller type LM guide axis moving system

Best-in-class high performance guideways (for all axes)

Speed → Reducing unnecessary time to move faster and stable

Rigidity → Strengthen axis moving during heavy cutting

Durability → Much better durability comparing with Ball LM Guide to realize precision moving and longer life time

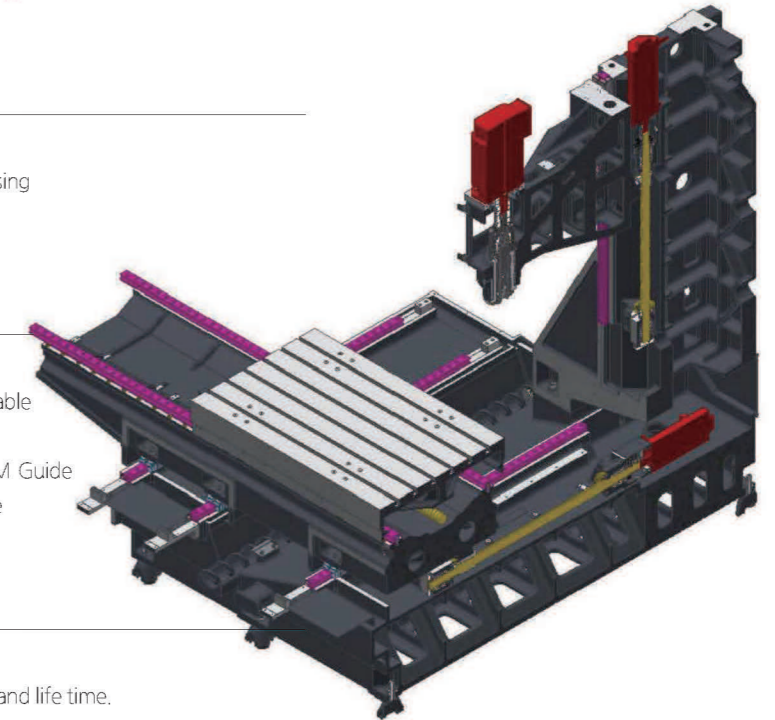

Applied 4 rows bearing for all axis(X-Y-Z)

High rigidity with 4 times the lifetime

By sustaining 8 bearings on each axis realizing high rigidity and life time.

Chip Conveyor & Coolant Tank

Removable coolant tank

Put coolant tank on left side of the machine for easy coolant exchange and cleaning as well as pump maintenance.

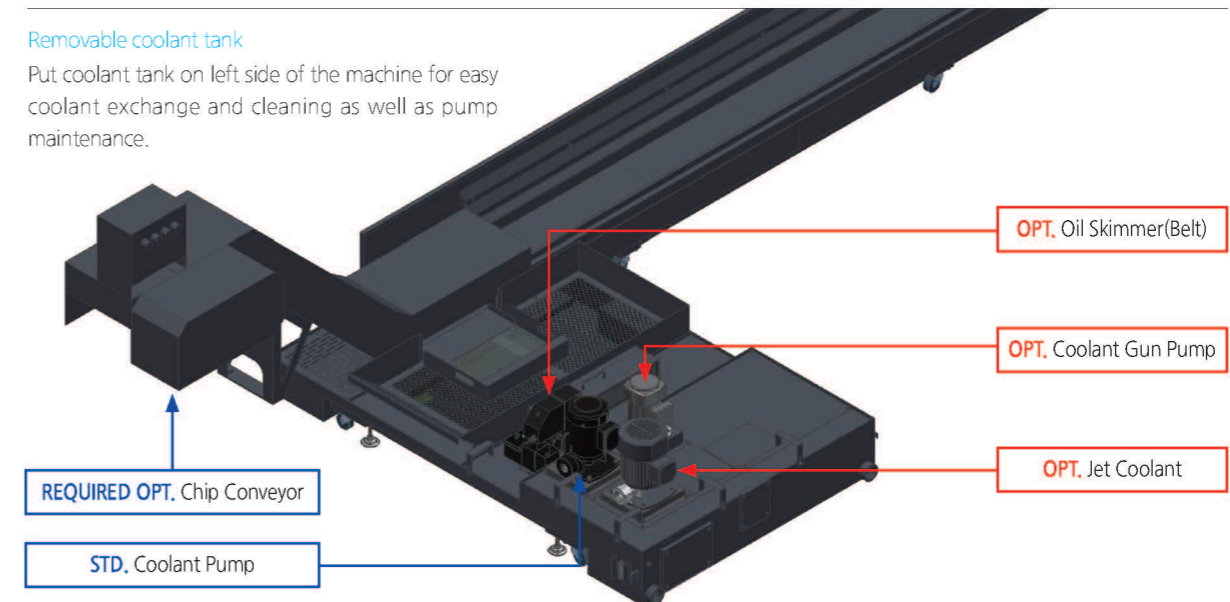

User friendly centralized control panel



- ① CRT : 10.4 inch color LCD
- ② Bigger BEZEL switch size :
50% larger than the conventional switch size
- ③ Addition of MG stand-by tool No
- ④ Addition of MG change button
- ⑤ Addition of 4th and 5th axis switch
- ⑥ Spindle Override
50~120% (15 step)
→ 50~150% (20 step change)
Feed Override
0~1260 (16 step)
→ 0~5000 (21 step change)
- ⑦ Addition of spare buttons for fixtures

Std. SMEC Package 2 (FAST DATA SERVER + AICC II)

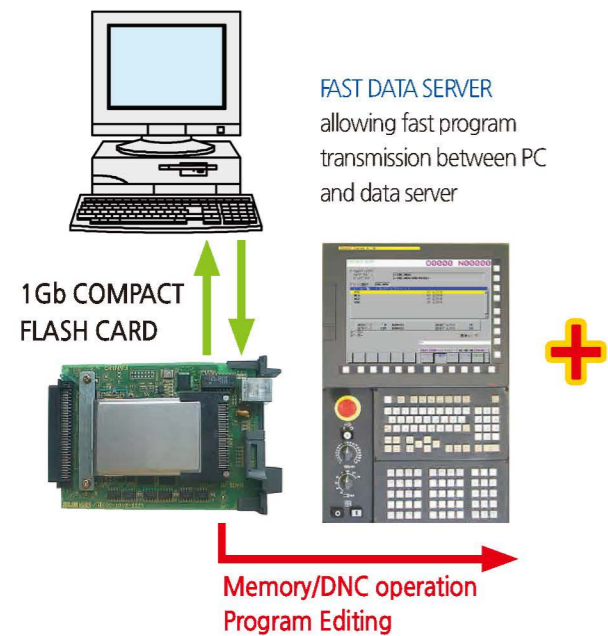

High Precision, High Speed AICC II

CNC MODEL	FOi-MF	31i
Block Look Ahead	200	200
Nano Interpolation	○	○
Decel Before Interpolation	Linear	Linear, Bell-Shaped
Acceleration Setting for Each Axis	○	○
Automatic Corner Deceleration	○	○
Radial Speed Clamp	○	○
Deceleration Speed Clamp	○	○

Cutting Capacity (BT40 11/18.5KW)

Face mill Carbon Steel (SM45C)

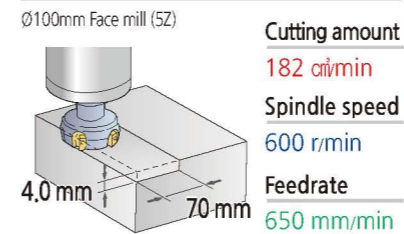

Face mill Aluminum (AL6061)

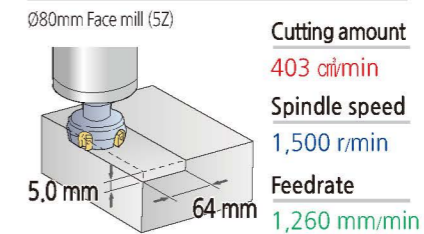

End mill Carbon Steel (SM45C)

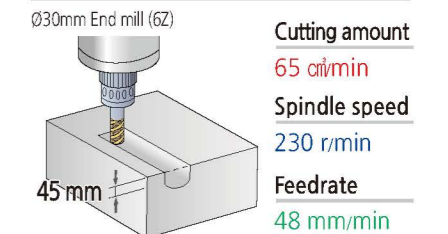

High Precision

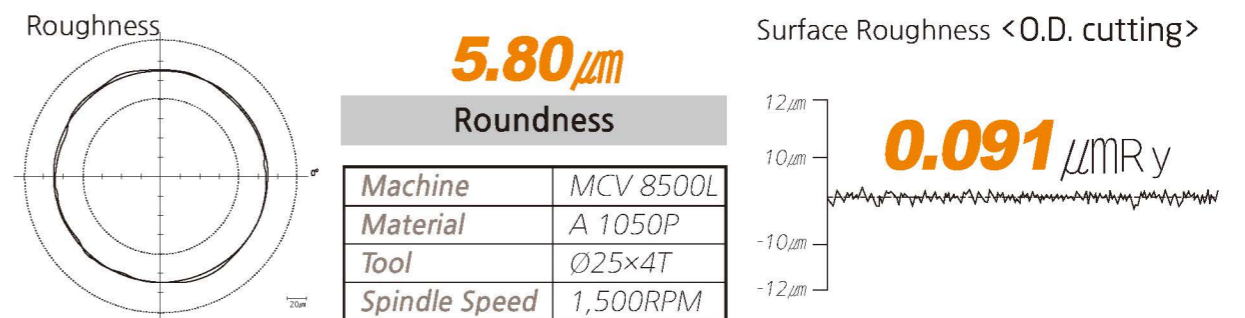

Optional Accessories



Machine Dimensions

Unit : mm

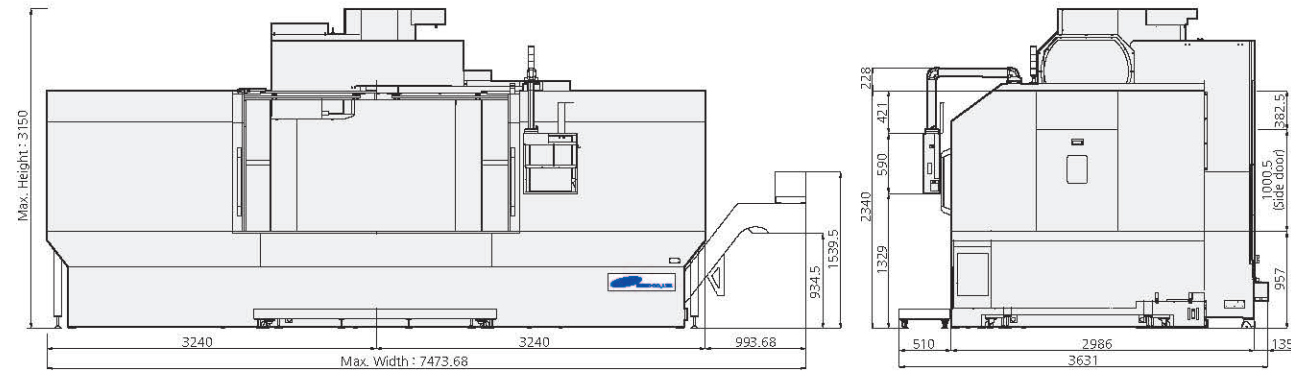
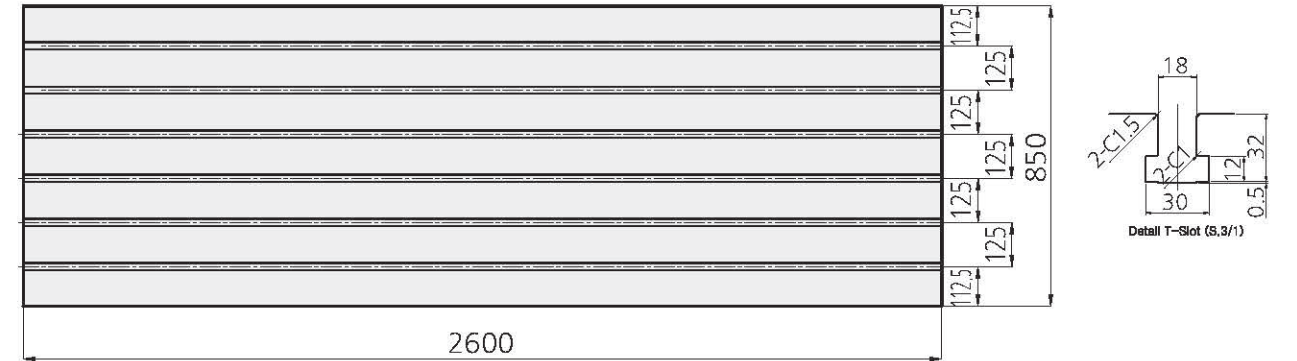

Table & T-Slot

Unit : mm



ATC Interference

Unit : mm

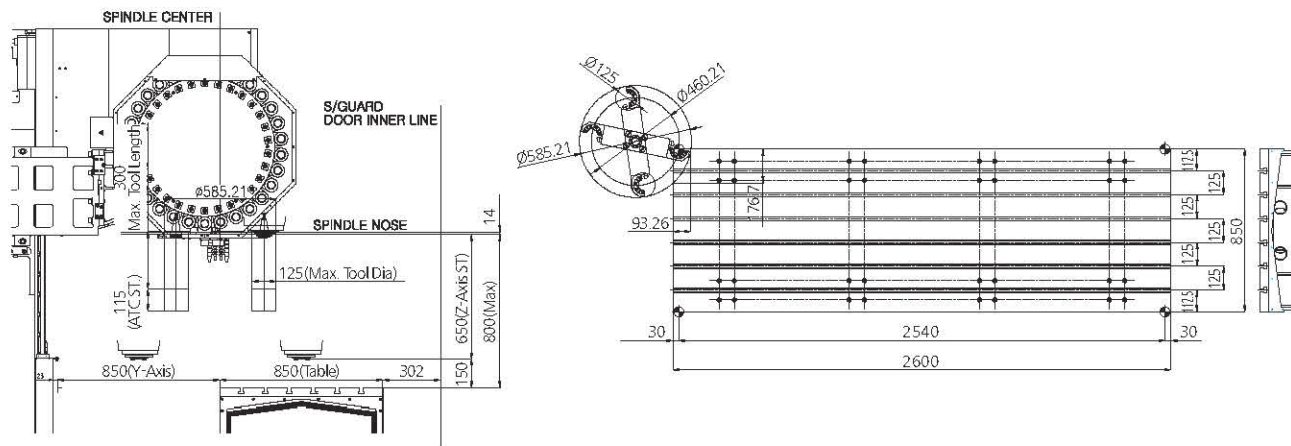

Tool Shank

Unit : mm

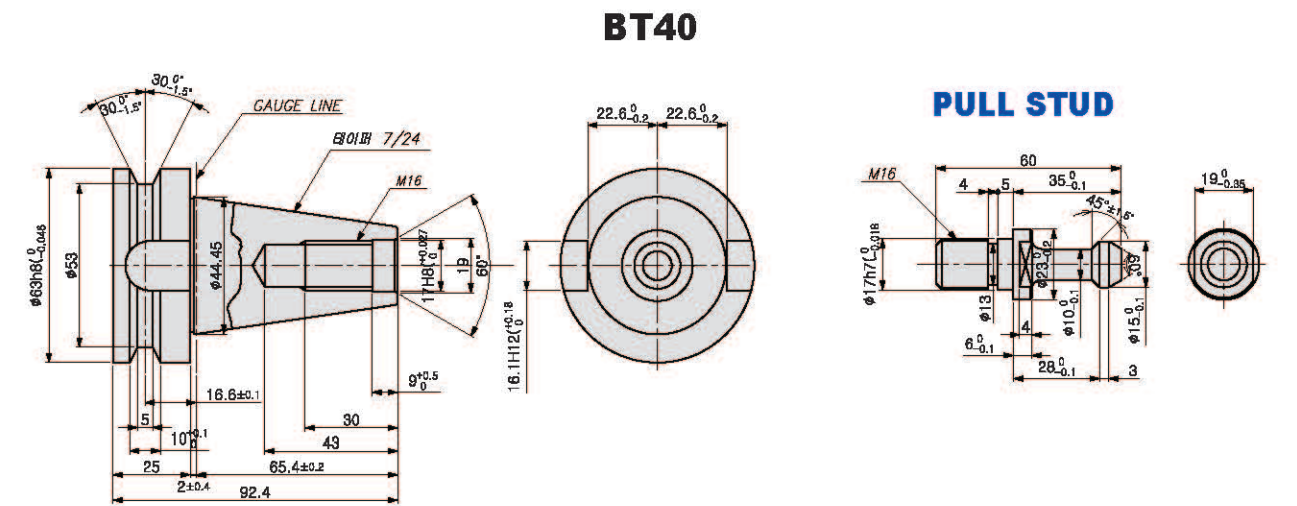

Machine Specification

DESCRIPTION		MCV 8500L
Travel	X-axis travel	mm 2,540
	Y-axis travel	mm 850
	Z-axis travel	mm 650
	Spindle to table surface	mm 150 ~ 800
Table	Table size	mm 2,600 x 850
	Max. Workpiece weight	kgf 2,000
	Table surface	mm 18H8 T-slot x p125 x 6ea
Spindle	Spindle speed	rpm 12,000
	Motor (Cont./Max)	kW 11/18.5
	Torque (Cont./Max)	N.m 70.1/117
Feedrate	X-axis Rapid traverse rate	m/min 30
	Y-axis Rapid traverse rate	m/min 30
	Z-axis Rapid traverse rate	m/min 24
ATC	Tool shank	- BBT40
	Pull stud	- MAS P40T-1
	Tool storage capacity	ea 30
	Max. Tool diameter (adjacent empty)	mm 80(125)
	Max. Tool length / weight	mm 300/8
	Tool-to-tool time	mm 1.3
	Tooling changing method	mm Double Arm Swing
Machine	Size (with Side Chip conveyor) LxWxH	mm 6,480(7,272) x 3,791 x 2,965
	Size (with Rear Chip conveyor) LxWxH	mm -
	weight	kg 16,000
	Coolant tank capacity	Liter 715
Electric power supply	kVA/V 32/220	
Controller	FANUC	

※Design and specifications subject to change without notice.

※():Option

Standard Accessories

- Coil conveyor (inside)
- Coolant system
- Door interlock
- Full splash guard with coolant tank
- Head nozzle
- Leveling parts (level plate, bolt, etc.)
- Lubrication system
- Manual/Part list (1set)
- Oil cooler
- Patrol lamp (3 colors)
- Portable MPG handle
- Rigid tapping
- Safety precaution name plate
- Spindle orientation
- Spindle override
- Standard tools and tool box
- Work light (LED lamp)

Optional Accessories

- Air blower
- Air gun
- Air conditioners
- Auto door
- Auto power off
- Chip bucket
- Chip conveyor (REQUIRED OPT.)
- Coolant blower
- Coolant chiller
- Coolant gun
- Coolant level switch
- Coolant pressure switch
- Counter (total, multi, tool, work)
- High column
- High pressure coolant
- Jet coolant
- Linear scale (X/Y/Z)
- M-code addition
- Oil mist collector
- Oil skimmer
- Robot interface
- Rotary table
- Through spindle coolant unit
- Tool measuring system
- Tool measuring tool
- Transformer
- Work light (addition)

NC Specifications / Fanuc Series

Item	Description	
Controlled axes	Controlled axes	X, Y, Z, (A)
	Max. simultaneously controlled axes	Positioning (G00)/ Linear Interpolation (G01) Circular Interpolation (G02, G03)
	Least input increment	0.001 mm / 0.0001"
Spindle function	Spindle speed control	S5 (5 Digit)
	Spindle speed override	50~120%
	Spindle orientation	M19
Feed function	Feedrate override (10% increase)	0~200%
	Dwell	G04
	Reference position return	G27 / G28 / G29 / G30
	Manual pulse generator	0.001/0.01/0.1mm
	Cutting feed override	0 ~ 5,000 mm/min
Tool function	Rapid traverse override	F0(Fine Feed), 25/50/100%
	Tool number command	T2 (2 Digit)
	Tool nose radius compensation	G43 / G44
	Tool radius compensation	G41 / G42
	Tool offset pairs	400 EA
Programming function	Tool geometry / wear offset	G90 / G91
	Canned cycle	G70 ~ G72 / G74 ~ G76 / G80 / G83 ~ G88
	Decimal point input	Able to input up to decimal point
	R command circular interpolation	R radial programming without using I, J, K values
	SUB program	4 phase
	Work coordinate system	G54 ~ G59
	Local / machine coordinate	G52 / G53
Max program dimension	±99999.999mm	
Tape Functions	M function	M3 (3 digit)
	Input code	ISO/EIA auto recognition
	I/O interface	RS232C
	Program storage space	512 Kbyte
Other features	Number of stored programs	400ea
	Display unit / MDI	10.4" color LCD / Soft input type MDI
	Synchronized tapping	Rigid tapping function
	Background editing	Program saving / editing during automatic operation
	Backlash compensation	Pitch error offset compensation for each axis
	Search function	Sequence / program number search
	Safety function	Emergency stop / overtravel
	Program test function	Machine Lock / Single Block
	Control function	Memory / MDI / Manual
	Mirror image	M75 / M76
Custom macro	#100 ~ #199, #500 ~ #999	