

■ NC Unit Specifications / FANUC Series

Item	Specification	Or-TF
Controlled axis	Max. feed axes	4 AXIS
	Feed axes	X/Z/(Cs)
	Max. simultaneously controlled axis	4
	Least command increment	0.001mm / 0.0001"
Operation functions	Pulse handle feed	X1, X10, X100
	Feedrate per minute	G98
	Feedrate per revolution	G99
Interpolation functions	Linear interpolation	G01
	Circular interpolation	G02, G03
	Dwell	G04
	Polar coordinate interpolation	G12.1, G13.1
	Cylindrical interpolation	G70.1
	Variable lead thread cutting	G34
	Continuous threading	
	Reference position return	G28
	Reference position return check	G27
Feed function	Rapid traverse rate override	F0, 25%, 50%, 100%
	Feedrate override	0~150%
Spindle function	Spindle orientation	
	Rigid tapping	
Tool functions	Tool number command	T4-Digt / T2-Digt
	Tool nose radius compensation	G40 ~ G42
	Tool offset pairs	
	Tool geometry/wear offset	GEOMETRY & WEAR DATA
	Tool life management	
	Tool path graphic display	
	Automatic tool offset	G36, G37
	Direct input of tool offset value measured B	
Program input	Absolute/incremental programming	
	Multiple repetitive cycle	G70 ~ G76
	Canned cycles	G90, G92, G94
	Inch/metric conversion	G20 / G21
	Program restart	
	Retraction for rigid tapping	
	Max. programmable dimension	±99999.999mm/±9999.9999"
	M function	M3 digit
	Custom macro	
	Canned cycle for drilling	
	Direct drawing dimension programming	
	Programmable data input	G10
	Optional block skip	
	Workpiece coordinate system	G52 ~ G59
Number of registerable programs	400EA	
Setting and display	Alarm & Operator history display	ALARM & OPERATION DISPLAY
	Run hour and parts count display	RUNNING TIME & PART NO. DISPLAY
	Display spindle & servo overload	SPINDLE & SERVO LOAD DISPLAY
	Self-diagnosis function	
	Extended part program editing	COPY, MOVE, CHANGE OF NC PROGRAM
	Display screen	10.4" color
Data input/output	Memory card input/output	
	USB memory input/output	
Editing operation	Part program storage size	512Kbyte(1280m)
Manual guide i	Manual Guide i	



140 East Ridgewood Ave. Suite 415, Paramus NJ 07652
Office: 833-777-7632, Sales: (586) 246-1432
Email: sales@esmecamerica.com

www.esmecamerica.com

◆ Design and specifications subject to change without notice.

SMEC

SL 6500 series

CNC TURNING CENTER



SMEC

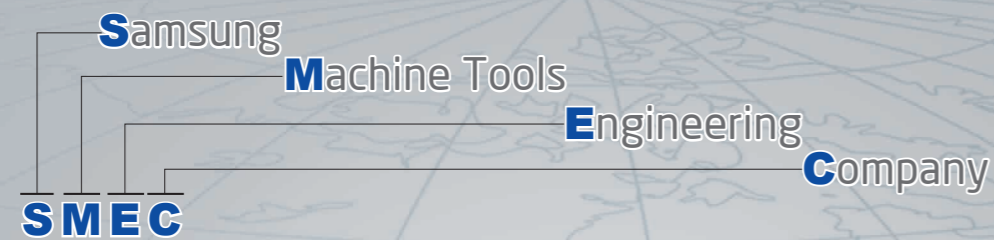

Company History

- 1988 - Started as **Samsung Heavy Industries** Machine Tools Business
- 1989 - Horizontal and vertical machining center technology partnership with **OKK Japan**
- 1991 - Turning center and vertical machining center technology partnership with **Mori Seiki**
- 1996 - 5-sided processing center technology partnership with **Toshiba**
- 1999 - Spun out from **Samsung Aerospace Industries** and established **SMEC Co., Ltd**
- 2018 - **SMEC America Corp** established to provide factory support to the distributor network and customers

SMEC'S Advanced Engineering and Machine Design

- Cast iron structure for superior dampening characteristics and thermal displacement
- Rigid 45 degree slant bed design for heavy-duty machining
- Torque tube design to minimize bending and twisting
- Integrated box ways for long-term rigidity and heavy-duty machining

SL 6500A/1000

SL 6500AM/1000

SL 6500A/3200

SL 6500AM/3200

SL 6500CX/3200



SL6500A(AM/CX) are heavy duty, ultra precision Turning Center, combined with SMEC's advanced technological features.

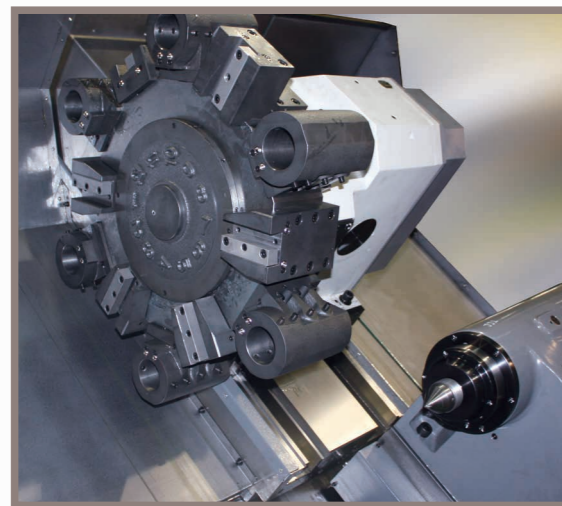

Spindle Speed[SL 6500CX/3200]
1,200[300] rpm

Spindle Motor(30min/cont.)
60/50 hp

Rapid Travel(X/Z)
472/709 ipm[SL 6500A(AM)/1000]
472/394 ipm[SL6500A(AM/CX)/3200]

Feed Motor(X/Z)
9.3/8 hp

Max. Turning Length
39.4 inch[SL 6500A(AM)/1000]
126.0 inch[SL 6500A(AM/CX)/3200]

Max. Turning Diameter
35.4 inch

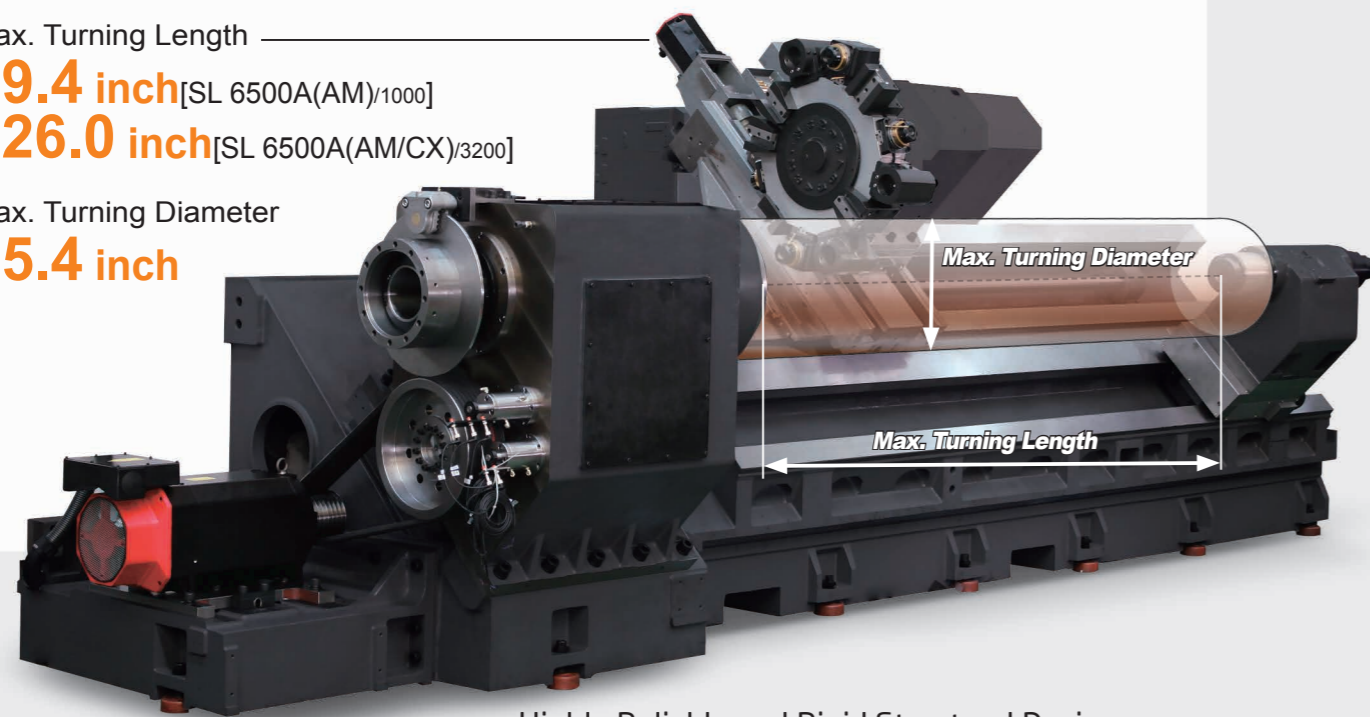

Highly Reliable and Rigid Structural Design

- One piece Meehanite casting with heavily ribbed torque tube design
- Rigid bed supports for powerful cutting
- Excellent vibration dampening and thermal displacement design

High Accuracy, High Rigidity Spindle

Main Spindle Motor and Geared Headstock(SL6500A)

The main spindle motor (60 hp) speed is reduced to 2.5 to 1, and its power is delivered to the spindle through a three-speed geared headstock to provide powerful torque (4055 ft.lbs)

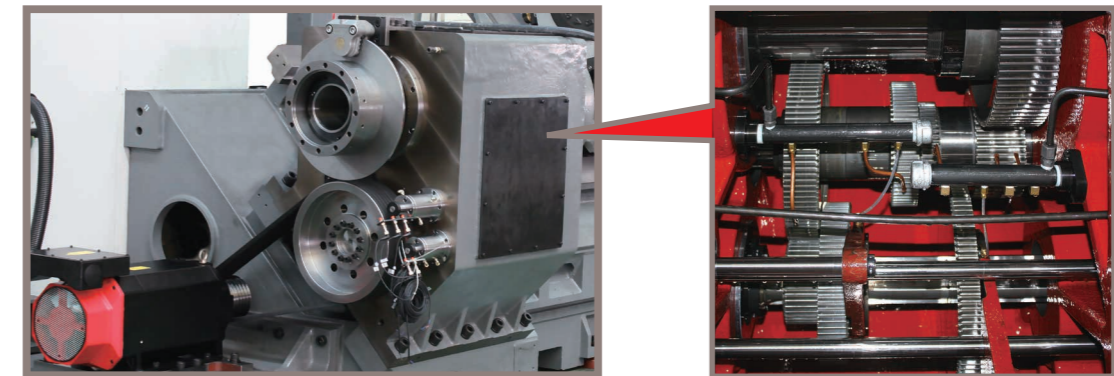

SPINDLE & HEADSTOCK

The Spindle and Headstock are machined and ground in a temperature controlled environment and assembled in a clean room.

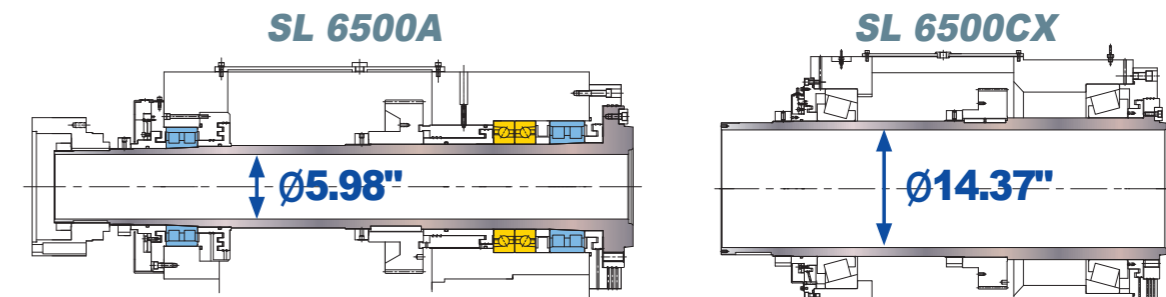

SL65 : Precision double row cylindrical roller bearings and angular contact ball bearings are located in the front of the spindle, and a double row of cylindrical roller bearings is located in the rear to ensure heavy cutting capabilities with precision.

SL80C : Precision taper roller bearings are located in the front and back of the spindle to ensure heavy duty cutting as well as extended bearing life even under extreme machining condition.

Spindle Power & Torque

Unit : inch

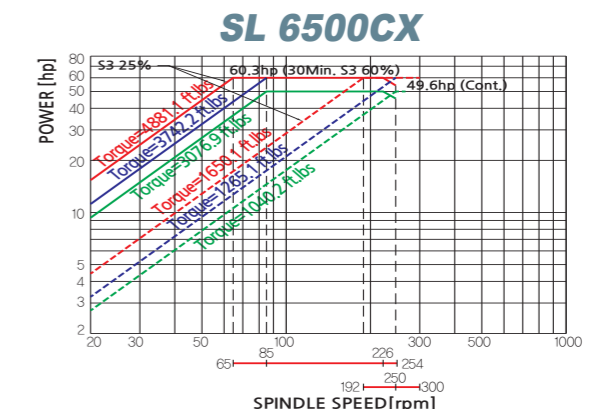
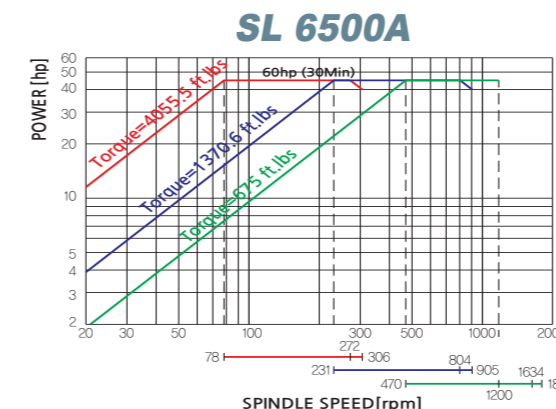

Machine Structure

BMT High Speed Turret

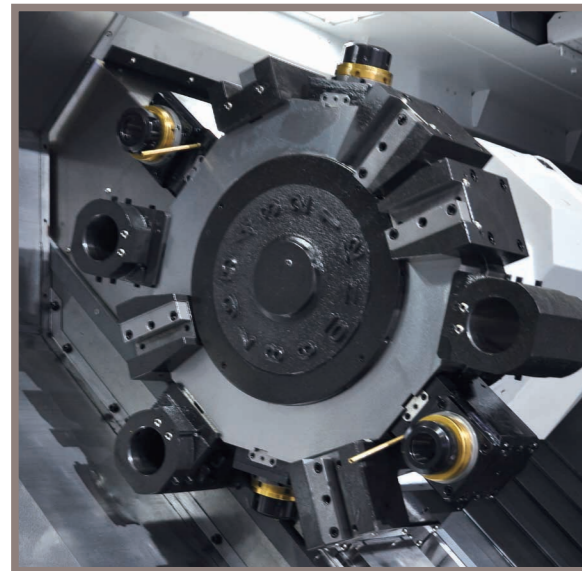

Indexing time
0.25 sec.

Number of tool positions
12 stations

BMT Milling Turret (M Type)

SL6500AM is equipped with standard 12-station BMT turret capable of accepting rotary tools at any station, providing flexible machining through various machining operations in just one set-up. Each BMT holder is securely tightened by 4 screws, allowing the turret to perform heavy-duty cutting, milling and drilling operations. Turret indexing is non-stop, bi-directional with a fast 0.25 second next station index time.

Turret Torque Diagram

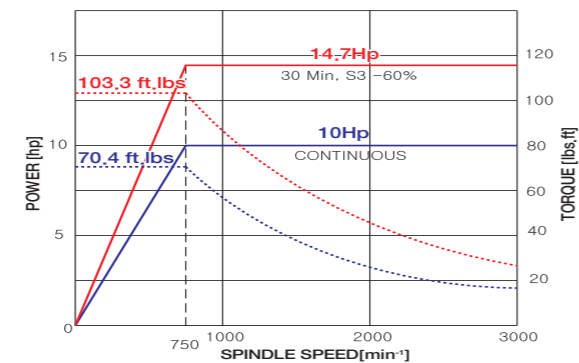

Easy Access to Rear Chuck & Clean Coolant Recirculation Design(SL 6500CX)

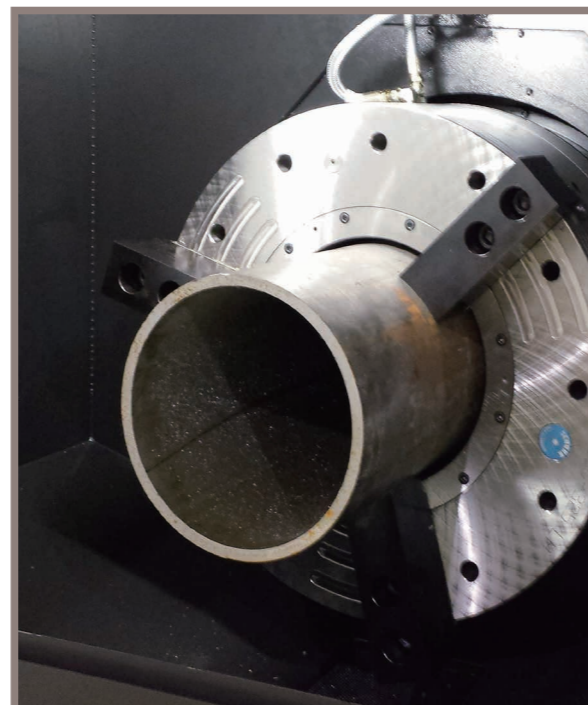

Machine Structure

Rigid 45 degree Slant Bed

45 degree slant torque tube design bed and wide guide slide way ensure long term rigidity and machining accuracy.

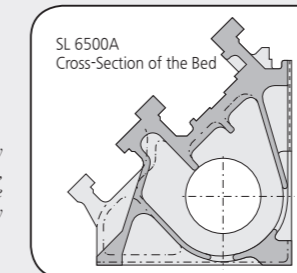

Featuring superior workability and chip-discharging capability, the bed is designed in a single tube structure boasting strong durability even in heavy-duty cutting.

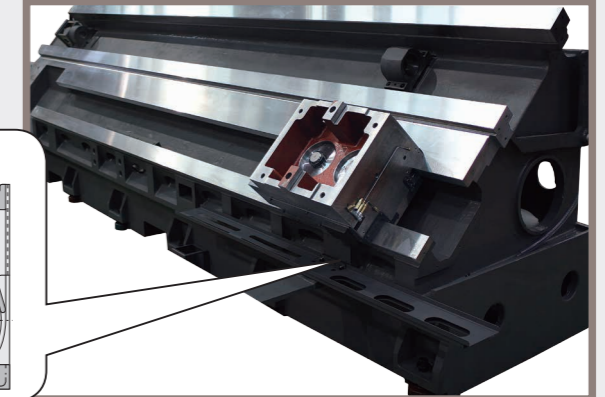

Swivel Operation Panel

Swiveled operation panel is designed to turn 90 degree, allowing operators for easier access to the control panel at any given position.

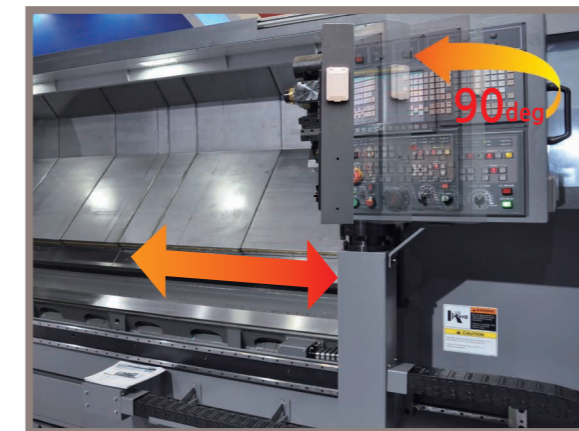

Pre-tensioned and Double Anchored Ballscrews

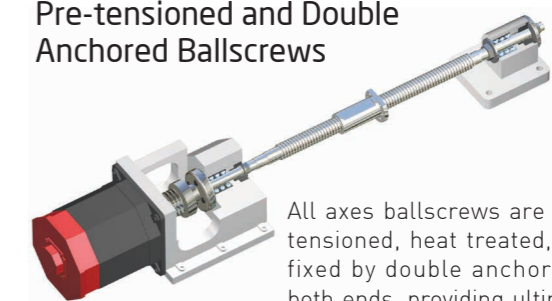

All axes ballscrews are pre-tensioned, heat treated, and fixed by double anchors on both ends, providing ultimate rigidity and minimal thermal growth.

Hexahedral Slide Way Frame

Wide integral way is machined from the casting, induction hardened and precision ground to ensure long-term rigidity, machining accuracy and heavy-duty machining.

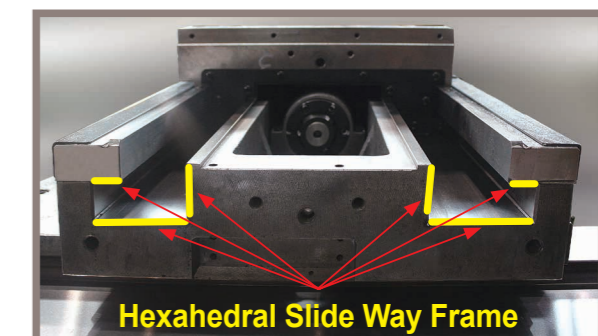

Tailstock

The programmable tailstock body mounted on wide guide ways ensure rigid work piece support.

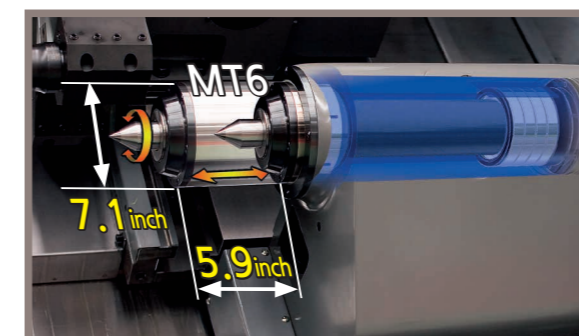

■ High Precision

Surface Roughness <O.D. cutting>

Roundness

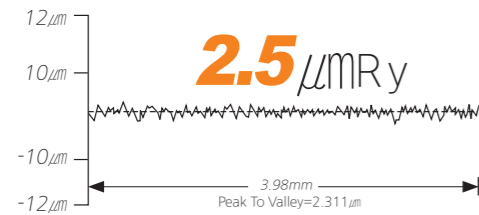

Cutting condition	
Tool	Diamond tool (nose radius 0.020 inch)
Material	AL150(Aluminum)
Cutting speed	650 fpm
Feedrate	0.0020 ipr
Depth of cut	0.005 inch
Outer diameter	7.9 inch
Filter	1-50

•Model : SL 6500A / 6500AM

■ Processing Speed

Turning Performance (material:SM45C) SL 6500A/1000

Heavy-duty cutting (O.D) <1 1/4 inch x 1 1/4 inch qualified tool>

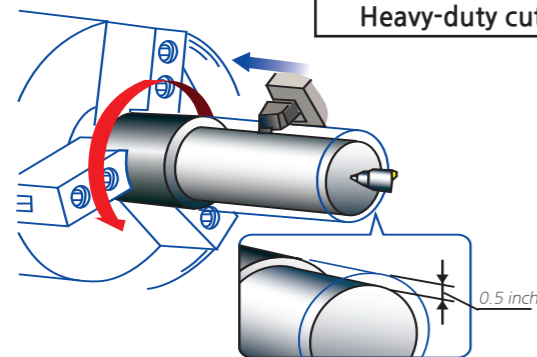

Spindle Speed
367 rpm
Cutting Speed
465 m/min
Depth Of cut
0.5 inch <Spindle Load 65%>
Feedrate
0.011 ipr

■ Standard Accessories

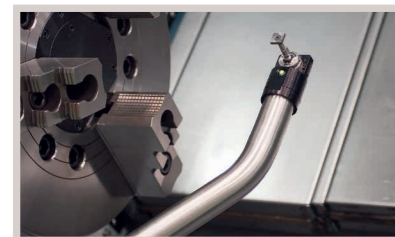

Tool Presetter



Automatic Lubricator

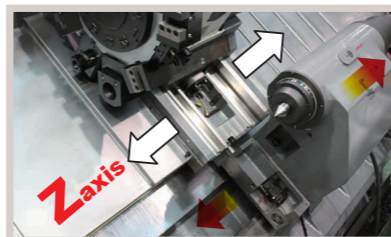

Programmable Tailstock

■ Optional Accessories



Auto Door



Chip Conveyor

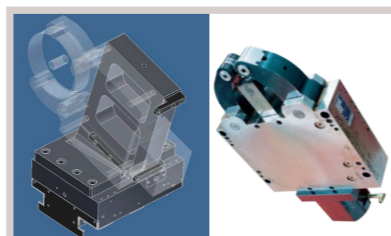

Steady Rest & Preparation

■ Tooling System

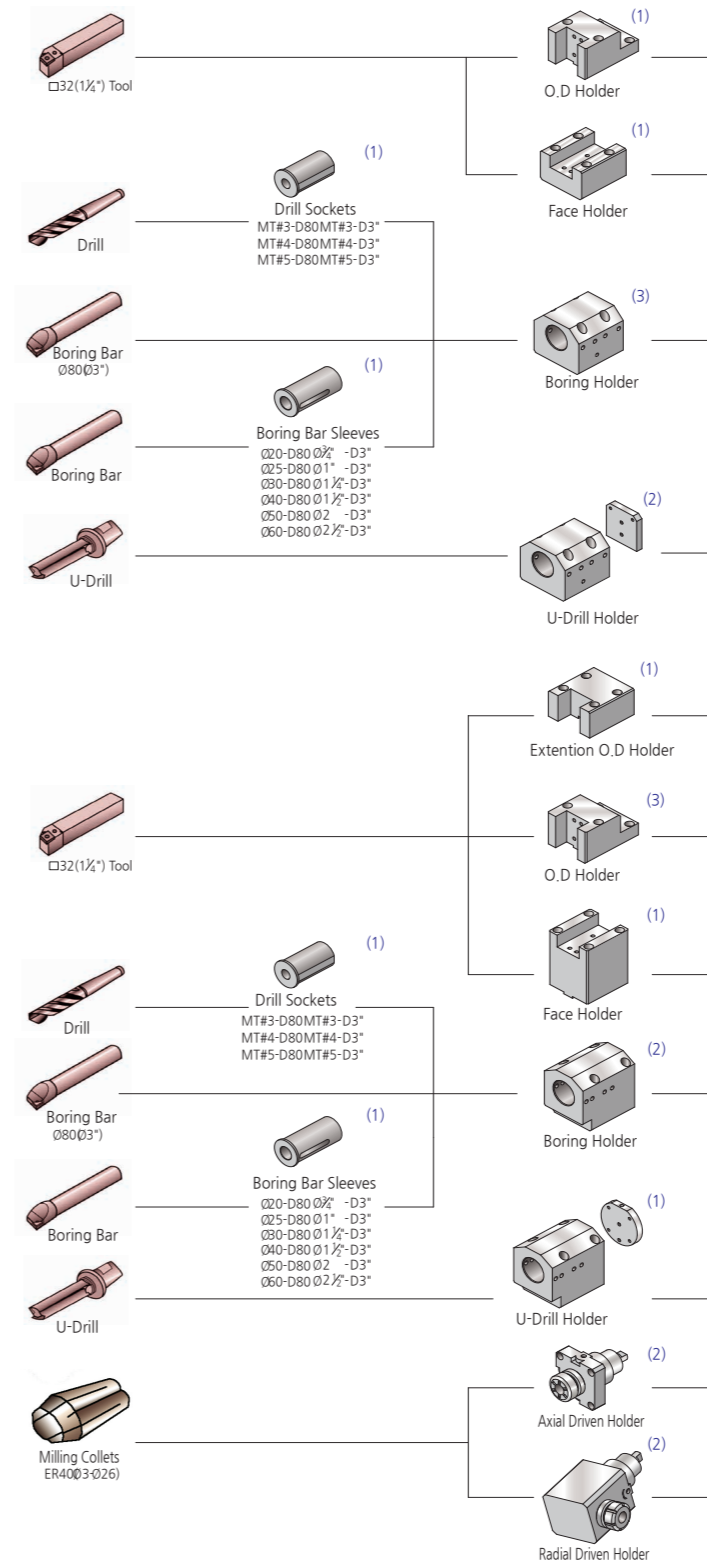

SL 6500A
SL 600CX

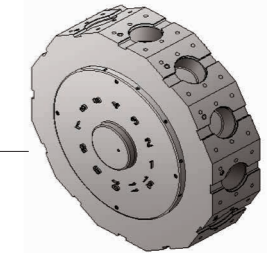

12-station Turret

SL 6500AM

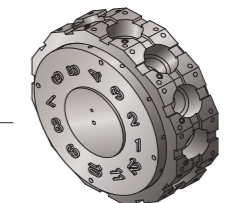

12-station Turret(BMT 85)

Machine Dimensions

SL 6500A(AM)/1000

Unit : inch

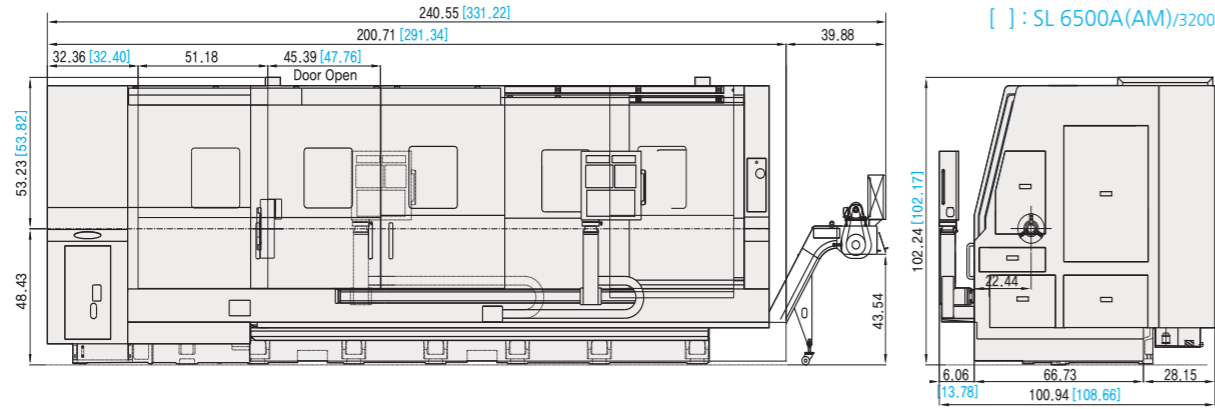

Turret Head Interference

STD TURRET (BMT 85)

MILL TURRET (BMT 85)

Unit : inch

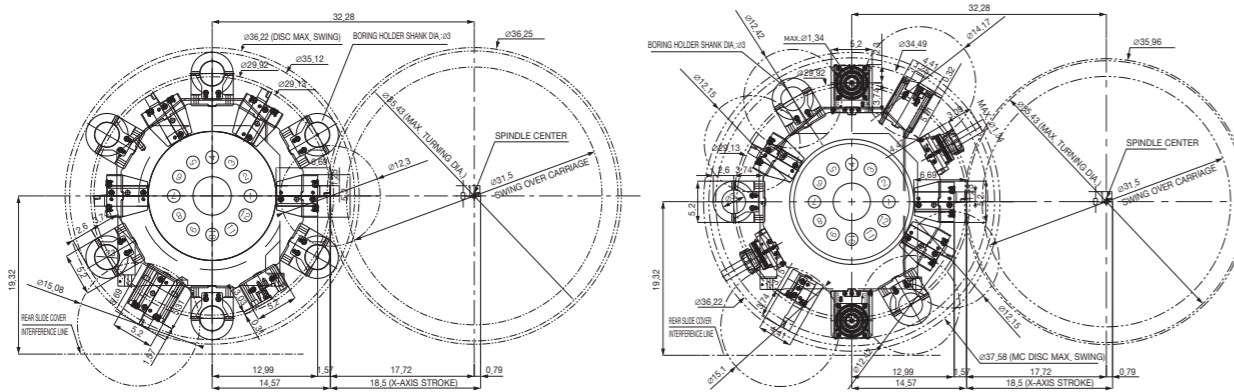

Work Range

SL 6500A/1000

SL 6500AM/1000

Unit : inch

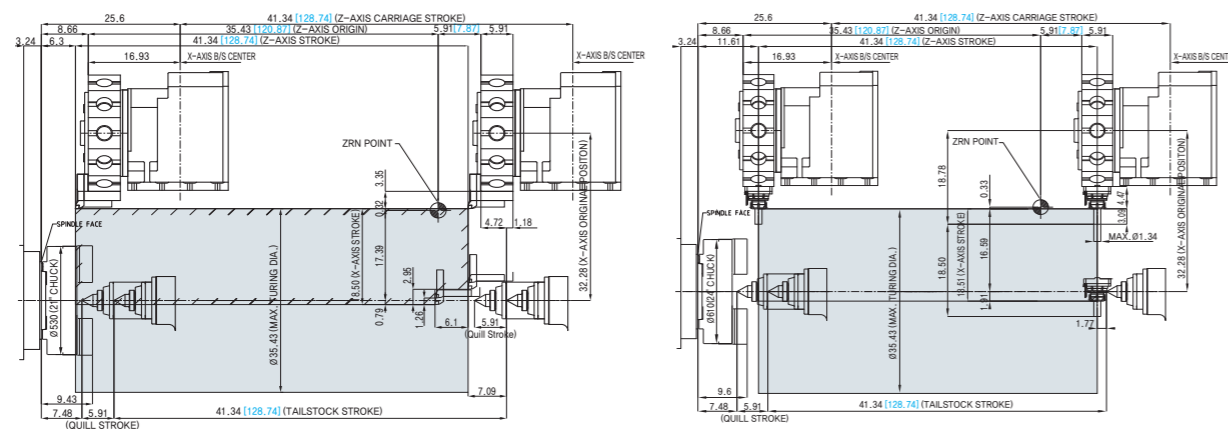

[] : SL 6500A/3200

[] : SL 6500AM/3200

Major Specifications

DESCRIPTION		SL 6500A/1000	SL 6500A/3200	SL 6500AM/1000	SL 6500AM/3200	SL6500CX/3200	
CAPACITY	Swing over bed	inch					Ø40.6
	Swing over saddle	inch					Ø31.5
	Recom. turning diameter	inch					20.9
	Max. machining diameter	inch					35.4
	Max. machining length	inch	39.4	126	39.4	126	126
Bar working diameter	inch	Ø5.5					-
TRAVELS	X-axis travel	inch					18.5
	Z-axis travel	inch	41.3	129	41.3	129	128.74
MAIN SPINDLE	Chuck size	inch					24" (Option)
	Spindle speed	rpm					1,200
	Spindle nose	ASA					A2-15
	Spindle through hole diameter	inch					5.98
	Min. spindle indexing angle	deg					0.001°
TURRET	Number of tool stations	ea					12[BMT85]
	Shank size for square tool	inch					1.25
	Shank diameter for boring bar	inch					3.0
	Indexing time	sec					0.25
	Rotary tool spindle speed	rpm					-
	Rotary tool spindle speed	rpm					3,000
FEED RATE	Rapid traverse (X/Z)	ipm	472 / 709	472 / 394	472 / 709	472 / 394	472 / 394
	X axis feed motor	hp	9.3				
MOTOR	Z axis feed motor	hp	8.0				
	Spindle drive motor(30min/cont.)	hp	60/50				
	Turret index motor	hp	3.4				
	Rotary tool spindle motor	hp	-				
TAILSTOCK	Tailstock travel	inch	41.34	128.74	41.34	128.74	128.74
	Quill diameter	inch	7.1				
	Quill bore taper	MT	MT-6(BUILT-IN)				
	Quill travel	inch	5.9				
ELECTRIC POWER SUPPLY	kVA/V	67/220					72/220
REQUIRED FLOOR SPACE	inch	201×101	291×109	201×101	291×109	291×109	
MACHINE HEIGHT	inch	102					
MACHINE WEIGHT	lbs	36,400	48,500	36,400	48,500	48,500	
CONTROLLER		Fanuc Oi-TF					

• Figures in inches are converted from metric measurements.
• Design and specifications subject to change without notice.

Standard Accessories

- COOLANT SYSTEM
- BUILT-IN WORK LIGHT
- SPLASH GUARD
- HAND TOOLS
- SOFT JAW 3 SETS
- 24" HYDRAULIC CHUCK

Optional Accessories

- TOOL HOLDERS
- LEVELING BLOCK
- TOOL PRESETTER
- PROGRAMMABLE TAILSTOCK
- HARD JAW 1 SET
- CHIP CONVEYOR
- AIR BLOW UNIT
- HYD. STEADYREST
- FRONT & REAR CHUCKS (SL80C)